

Q.reader cabinet

Performance Monitoring and Control



Key features:

- Q.reader cabinet is a modular data logging and control system
- Data logger with integrated plant control: Q.reader central
- 100 - 240VAC/24 DC power supply
- UPS with monitoring
- VPN router
- DSL, GSM 3G or Satellite communication
- Industrial network switch
- 4 RS485 fieldbus interface up to 115,2 kbps
- Industrial Ethernet Switch
- FX fiber optics multimode or single mode to connect to Gantner Fieldpoint Extension
- Connectivity Protocols from all leading inverter manufacturers are integrated I/O devices (e.g. weather stations, medium voltage parameters)
- SPD's for all communication ports
- Electromagnetic compatibility EN 61000-4, EN 55011
- IP65 housing
- Wall-/rack mounted configuration

Effective PV Monitoring requires constant, solid and traceable PV Plant monitoring data in order to determine actual performance and fulfil owner/investor expectations.

Operators are interested to identify errors and losses in a reliable way to trigger appropriate actions for maximizing energy harvest during the total system lifetime.

The "Q.reader cabinet" is a solution which can make the logging and control of all required PV plant information: string level (current, voltage), inverter data, meteorological data from weather stations, grid measurements and other state variables (switch gear, transformer status). At the same time, it also acts as the power controller for the grid operator.

Principal data acquisition and control concept of utility scale PV power plant

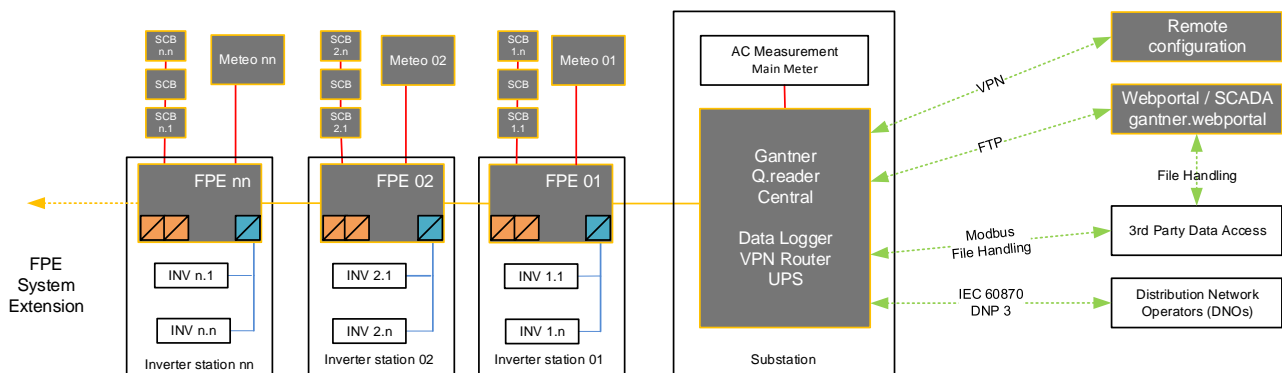

Communication cable:	Converter:	Abbreviation:
— RS485 8x2x0,5 TP shielded	 Fiber/Ethernet	FPE Field Point Extension
— Fiber optics cable 8x 125 Multimode	 Ethernet/RS485	SCB String Combiner Box
— Ethernet cable		Meteo Meteostation and panel temperature
— Remote connection		INV Inverter



Effective PV Monitoring requires constant, solid and traceable PV Plant monitoring data in order to determine actual performance and fulfil owner/investor expectations.

Operators are interested to identify errors and losses in a reliable way to trigger appropriate actions for maximizing energy harvest during the total system lifetime.

The “Q.reader” is a data logger which can make the logging and control of all required PV plant information: string level (current, voltage), inverter data, meteorological data from weather stations, grid measurements and other state variables (switch gear, transformer status). At the same time, it also acts as the power controller for the grid operator.

This accurate data acquisition and control concept is inverter independent and gives feedback about losses due to inverter malfunction, soiling, shading, PV Module degradation etc. .

The Linux based platform can control up to 100MW plants with just one controller and fulfils all international requirements as the IEC 60870 (communication protocol for supervisory control and data acquisition) for reactive power, ramp rates, etc. or Germany’s BDEW (“Erzeugungsanlagen im Mittelspannungsnetz”). Data collection can be down to one second or more, which is often required by utilities to zoom for grid impacts tests.

Signal conditioning, data storage and transfer, compressing, and communication in many ways are the strengths of this flexible data solution. For communication industry standard Modbus protocols for easy and fast integration is used which enables reliable data exchange within the network. For longer communication distances fiber optic technology is used. Data transfer is possible by cable (Ethernet/ LAN) or wireless (GPRS/3G or 4G, WiFi) – the loggers meet all standard security requirements (SSL) with lowest power consumption.

The data acquisition system grows with the requirements and distributed Q.series measurement modules can be integrated at any time.

Key features:

- **Data logger with integrated Plant control for reactive power, ramp rates etc.**
Up to 100MW of logging and control per device
Control according to IEC 60870 (communication protocol for supervisory control and data acquisition)
- **Analog and digital inputs and outputs via Q.series I/O modules**
24 bit resolution, sample rate 0.1 s up to 24 h
- **4 x RS485 fieldbus interface**
Up to 115,2 kbps
- **Ethernet interface for configuration and data transfer**
TCP/IP, UDP, FTP Server and FTP Client functionality
Configurable functions
- **Grid interaction**
based on IEC 60870, DNP 3
- **Connectivity**
Protocols from all leading inverter manufacturers are integrated
I/O devices (e.g. weather stations, medium voltage parameters)
- **Data memory with individual logging interval**
8GB flash
0.1 s up to 24 h, individual per channel
- **Configurable monitoring**
with auto-alarming via e-mail or SMS
local arithmetic functions
- **Direct link to the gantner.webportal for worldwide data access**
Operating system Linux

